

蓋詳圖

熱浸鍍鋅格柵板製造說明：

1. 熱浸鍍鋅格柵板蓋(封邊除外)須用高週波全自動熔接機熔接，不得造成母材熔蝕
2. 材質：全部使用 SS-400 鋼材
3. 格柵板製造成型後，均須熱浸鍍鋅做表面處理，鍍鋅量：610 g/m² 以上
4. 封邊：格柵板兩邊焊以 h*6 之扁鋼為邊框，焊渣應清除乾淨

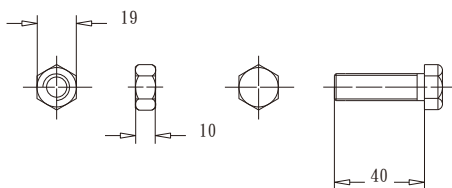

螺絲螺帽詳圖

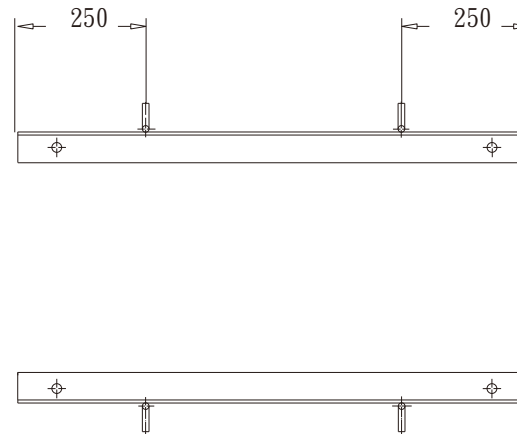

框座詳圖

CFB型 固定式橫斷溝蓋..... 格柵板規格

本工程採用有 符號者	採用符號	型式	溝距 (mm)	格柵板寬(mm)		格柵板高度 (h)
				D (框)	d (蓋)	
○	CFB-30	300	422	400	1-50	
○	CFB-35	350	472	450	1-55	
○	CFB-40	400	522	500	1-55	
○	CFB-45	450	572	550	1-65	
○	CFB-50	500	622	600	1-65	
○	CFB-55	550	672	650	1-75	
○	CFB-60	600	722	700	1-75	

 進豐晟企業股份有限公司 <small>CHIN FENG CHENG</small>	
規格	CFB-2L
圖號	CFB-1050606